

WedgeRock RP PRODUCT SHEET

700140 Rev-02

PLANETARY GEAR SOLUTIONS



Features, Options & Configurability

- | | |
|---|---|
| <ul style="list-style-type: none"> • Capable of reducing turns to cycle or time to close by 5X over conventional quarter-turn solutions due to increased efficiency and wide range of ratio options. • Optionally Self-Locking • Mechanical stops for quarter turn rotation, $\pm 5^\circ$ adjustment at each stop • 90% filled, Greased for life, no maintenance • Elastomer seals at all ingress points, designed and tested to IP68 • Input shaft projection Parallel or Perpendicular to output with addition of Bevel or Miter gear • Input lockout • Meets requirements of AWWA C500, C509 & C515 • Available Certifications: <ul style="list-style-type: none"> ○ Buy America Compliant ○ AWWA Compliant ○ ATEX Compliant | <ul style="list-style-type: none"> • Modular design accommodates; <ul style="list-style-type: none"> ○ Quarter-Turn ○ Multi-Turn ○ Rising Stem ○ Non-Rising Stem ○ Subsea <ul style="list-style-type: none"> ▪ Deep water ▪ Shallow water • Motorized and Manual input options • Buried Service prep • Risers and Adaptors • Temperature range and materials configured per application • Machined for direct mount <ul style="list-style-type: none"> ○ Standard Flanges to MSS SP101/MSS SP102 & ISO 5211/ISO 5210 ○ Infinite Custom Bolt Pattern Options |
|---|---|

PURPOSE ENGINEERED - QUALITY MANUFACTURED - PERFORMANCE TESTED

The information in this document is subject to change without notice. Updated documents can be requested or obtained from our website.

WedgeRock QUARTER-TURN RP SERIES

PERFORMANCE

While the RP planetary gear is designed for traditional multi-turn applications, we've included some extra features. The quarter-turn version of the RP is designed with performance in mind versus traditional wormgears..



Motorized Application, Optimized Power Consumption

	Required Gearbox Rating	Gearbox Ratio	Gearbox Mechanical Advantage	Gearbox Efficiency	Turns to Close	Input Torque Required	Power Required
	IN-LBS (NM)					IN-LBS (NM)	HP (KW)
Standard Efficiency Wormgear	95,000 (10,735)	168	46	23%	42	2088 (236)	3.3 (2.5)
WedgeRock Planetary Gear	95,000 (10,735)	165	151	91%	41	630 (71)	1.0 (0.7)

Motorized Application, Optimized Time to Operate

	Required Gearbox Rating	Gearbox Ratio	Gearbox Mechanical Advantage	Gearbox Efficiency	Turns to Close	Time to Operate 1/4 Turn @ 100 RPM
	IN-LBS (NM)					Seconds
Standard Efficiency Wormgear	95,000 (10,735)	168	46	27%	42	25
WedgeRock Planetary Gear	95,000 (10,735)	45	42	94%	11	7

Manual Application, Optimized Turns to Operate

	Required Gearbox Rating	Gearbox Ratio	Gearbox Mechanical Advantage	Gearbox Efficiency	Handwheel Diameter	Turns to Operate
	IN-LBS (NM)				IN (MM)	
Standard Efficiency Wormgear	95,000 (10,735)	504	119	24%	36 (914)	126
WedgeRock Planetary Gear	95,000 (10,735)	75	68	91%	36 (914)	19

Value Proposition

Conventional wormgears use inefficient gear design as self-locking feature. WedgeRock uses a patented mechanical bidirectional clutch called PolyLock™ making our high efficiency planetary gears self-locking. The PolyLock clutch allows torque from input to act on drivetrain in clockwise or counterclockwise direction while providing mechanical brake force if backdriving torque is applied to the output by valve or other actuated device.

Motorized application can be optimized using WedgeRock planetary gears, for faster close times, or reducing electric actuator frame size. Manual applications can be optimized to reduce number of turns to operate extending manually operated valve size, reducing installation and maintenance cost.

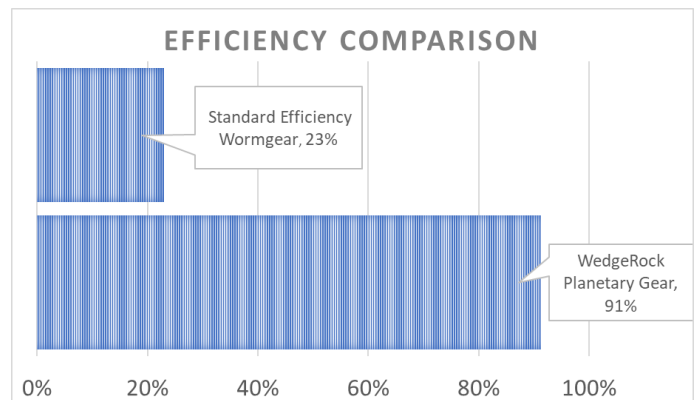

WedgeRock RP SERIES

GENERAL OVERVIEW

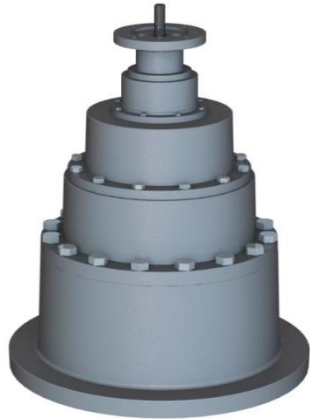

RP SERIES PLANETARY REDUCTION GEAR			
MODEL	INPUT SHAFT DIAMETER (KEY PER ANSI B17.1)	MIN STANDARD INPUT FLANGE	MAX STANDARD INPUT FLANGE
	IN (MM)		
RP5	1.00 / 1.50 (25.4 / 38.1)	F/FA10	F/FA16
RP6	1.00 / 1.50 (25.4 / 38.1)	F/FA14	F/FA16
RP8	1.50 / 2.00 (38.1 / 50.8)	F/FA16	F/FA25

MANUAL AND MOTORIZED OPERATION

MODEL	TORQUE RATING			MAX BORE W/ SQUARE KEY PER ANSI B17.1	MAX BORE W/ RECTANGULAR KEY PER ANSI B17.1	MAX CIRCUMSCRIBED DIAMETER OF DRIVE FEATURE	MAX STEM ENGAGEMENT	STANDARD FLANGE
	200 CYCLES 1.5X S.F. ²	1,000 CYCLES 2.0X S.F. ²	10,000 CYCLES 2.5X S.F. ²					
	IN-LBS (NM)	IN-LBS (NM)	IN-LBS (NM)					
RP5	13,333 (1,507)	10,000 (1,130)	8,000 (904)	2.00 (50.8)	2.00 (50.8)	2.51 (63.7)	4.00 (101.6)	F10/FA10 F16/FA16
RP6	37,333 (4,219)	28,000 (3,164)	22,400 (2,531)	3.50 (88.9)	3.63 (92.1)	4.39 (111.6)	5.28 (134.1)	F16 ¹ /FA16 ¹ F25/FA25
RP6H	60,000 (6,780)	45,000 (5,085)	36,000 (4,068)	3.50 (88.9)	3.63 (92.1)	4.39 (111.6)	5.28 (134.1)	F16 ¹ /FA16 ¹ F25/FA25
RP8	133,333 (15,067)	100,000 (11,300)	80,000 (9,040)	4.00 (101.6)	4.25 (108.0)	5.02 (127.5)	6.00 (152.4)	F25/FA19 ¹ F30/FA30
RP9	233,333 (26,367)	175,000 (19,775)	140,000 (15,820)	4.75 (120.7)	5.25 (133.4)	6.15 (156.1)	7.00 (177.8)	F25/FA19 ¹ F35/FA36
RP10	320,000 (36,160)	240,000 (27,120)	192,000 (21,696)	6.25 (158.8)	6.50 (165.1)	7.78 (197.6)	7.80 (198.1)	F25 ¹ /FA25 ¹ F40/FA40
RP12	533,333 (60,267)	400,000 (45,200)	320,000 (36,160)	7.25 (184.2)	7.50 (190.5)	9.01 (228.8)	8.34 (211.8)	F30 ¹ /FA30 ¹ F48/FA48
RP14	1,000,000 (113,000)	750,000 (84,750)	600,000 (67,800)	8.00 (203.2)	8.50 (215.9)	10.00 (254.0)	9.50 (241.3)	F35 ¹ /FA35 ¹ F60/FA60
RP18	1,800,000 (203,400)	1,350,000 (152,550)	1,080,000 (122,040)	9.75 (247.7)	10.50 (266.7)	12.25 (311.2)	13.80 (350.5)	F48 ¹ /FA48 ¹ F60/FA60
RP24	3,000,000 (339,000)	2,250,000 (254,250)	1,800,000 (203,400)	10.00 (254.0)	10.50 (266.7)	12.48 (317.0)	16.00 (406.4)	F48 ¹ /FA48 ¹ AS NEEDED
RP36	6,000,000 (678,000)	4,500,000 (508,500)	3,600,000 (406,800)	14.00 (355.6)	15.00 (381.0)	17.49 (444.1)	16.00 (406.4)	F60 ¹ /FA60 ¹ AS NEEDED

1) Spigot diameter does not fit on standard flange

2) Published safety factor for gearbox design. Application should be sized to published torque rating and include any application safety factor

WedgeRock RP SERIES

ENVELOPE DIMENSIONS

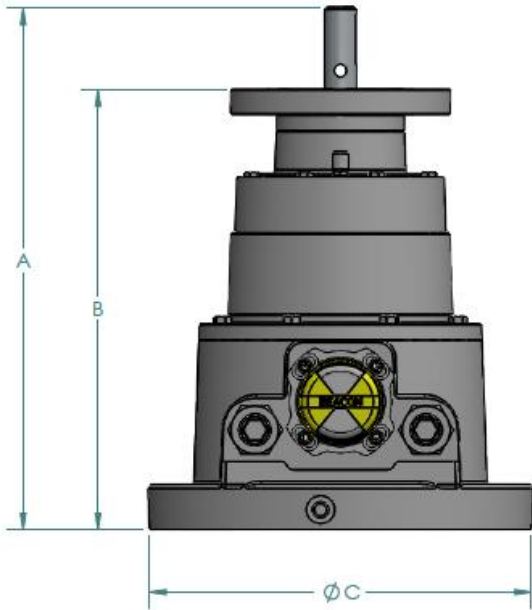

RP ENVELOPE DIMENSIONS AND WEIGHT				
MODEL	A	B	C	WEIGHT
	IN (MM)	IN (MM)	IN (MM)	LBS (KG)
RP5	13.1 (333)	10.5 (267)	8.4 (213)	72 (33)
RP6	15.2 (386)	13.1 (333)	12.0 (305)	131 (59)
RP6 + RP5	16.4 (417)	13.8 (351)	12.0 (305)	142 (64)
RP6H + RP5	16.4 (417)	13.8 (351)	12.0 (305)	148 (67)
RP8	18.4 (467)	16.9 (429)	15.0 (381)	268 (122)
RP8 + RP6	19.7 (499)	18.4 (467)	15.0 (381)	262 (119)
RP8 + RP6 + RP5	21.7 (551)	19.1 (485)	15.0 (381)	265 (120)
RP9 + RP8	23.9 (606)	22.4 (568)	16.8 (427)	481 (218)
RP9 + RP8 + RP5	23.8 (604)	21.2 (539)	16.8 (427)	390 (177)
RP10 + RP8	27.3 (694)	25.8 (656)	18.8 (477)	660 (299)
RP10 + RP8 + RP5	27.3 (693)	24.7 (627)	18.8 (477)	628 (285)
RP12 + RP8	27.8 (705)	26.3 (667)	22.3 (565)	832 (377)
RP12 + RP8 + RP6	29.0 (738)	27.8 (706)	22.3 (565)	826 (375)
RP12 + RP8 + RP6 + RP5	31.1 (789)	28.5 (724)	22.3 (565)	829 (376)
RP14 + RP10 + RP6	34.1 (867)	32.9 (835)	27.8 (705)	1403 (636)
RP14 + RP10 + RP6 + RP5	33.6 (853)	36.1 (918)	27.8 (705)	1406 (638)
RP18	AVAILABLE UPON REQUEST			
RP24	AVAILABLE UPON REQUEST			
RP36	AVAILABLE UPON REQUEST			
RP36 + RP18	AVAILABLE UPON REQUEST			
Dimensions represent most common configurations. Other dimensional configurations possible.				
Weight may vary with final configuration.				

WedgeRock RP SERIES

AVAILABLE RATIOS

COMMON RATIOS FOR RP5 & RP6

RATIO ¹ [MOST COMMON]	2.50	[2.6]	2.71	2.78	2.85	[3.00]	3.18	[3.29]	3.40	3.67	4.00	[4.20]	4.43	[5.00]	5.80	[6.33]	[9.00]
MECHANICAL ADVANTAGE ² [MOST COMMON]	2.4	[2.5]	2.6	2.7	2.8	[2.9]	3.1	[3.2]	3.3	3.6	3.9	[4.1]	4.3	[4.9]	5.6	[6.1]	[8.7]

COMMON RATIOS FOR RP8-RP24

RATIO ¹ [MOST COMMON]	[2.5]	2.60	2.71	2.78 [^]	2.85	[3.00]	3.18	3.29 [^]	3.40	3.67	[4.00]	4.20 [^]	4.43	[5.00]	5.80 [^]	6.33 ^{^^}	9.00 ^{^^^}
MECHANICAL ADVANTAGE ² [MOST COMMON]	[2.4]	2.5	2.6	2.7	2.8	[2.9]	3.1	3.2	3.3	3.6	[3.9]	4.1	4.3	[4.9]	5.6	6.1	8.7

COMMON RATIOS FOR RP36

RATIO ¹ [MOST COMMON]	2.44	2.63	2.86	3.17	3.60	4.25	[5.33]	6.20	[^] Catalog torque rating to be reduced by 20% using this ratio								
MECHANICAL ADVANTAGE ² [MOST COMMON]	2.3	2.5	2.7	3.0	3.4	4.0	[5.1]	5.9	^{^^} Catalog torque rating to be reduced by 40% using this ratio								
									^{^^^} Catalog torque rating to be reduced by 60% using this ratio								

1) Additional ratios available upon request.

2) Mechanical advantage can fall short of published value by 10% until gearbox has worn in. Wear in should occur within 10 cycles.

WedgeRock HANDWHEELS

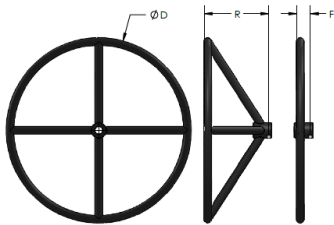

D	R	F
IN	IN	IN
(MM)	(MM)	(MM)
6	5.25	1.75
(152)	(133)	(44)
12	5.25	1.75
(305)	(133)	(44)
18	6.25	1.75
(457)	(159)	(44)
24	8.38	1.75
(610)	(213)	(44)
30	10.00	1.75
(762)	(254)	(44)
36	9.63	1.75
(914)	(244)	(44)
42	10.13	1.75
(1,067)	(257)	(44)

HANDWHEEL SIZE CHART

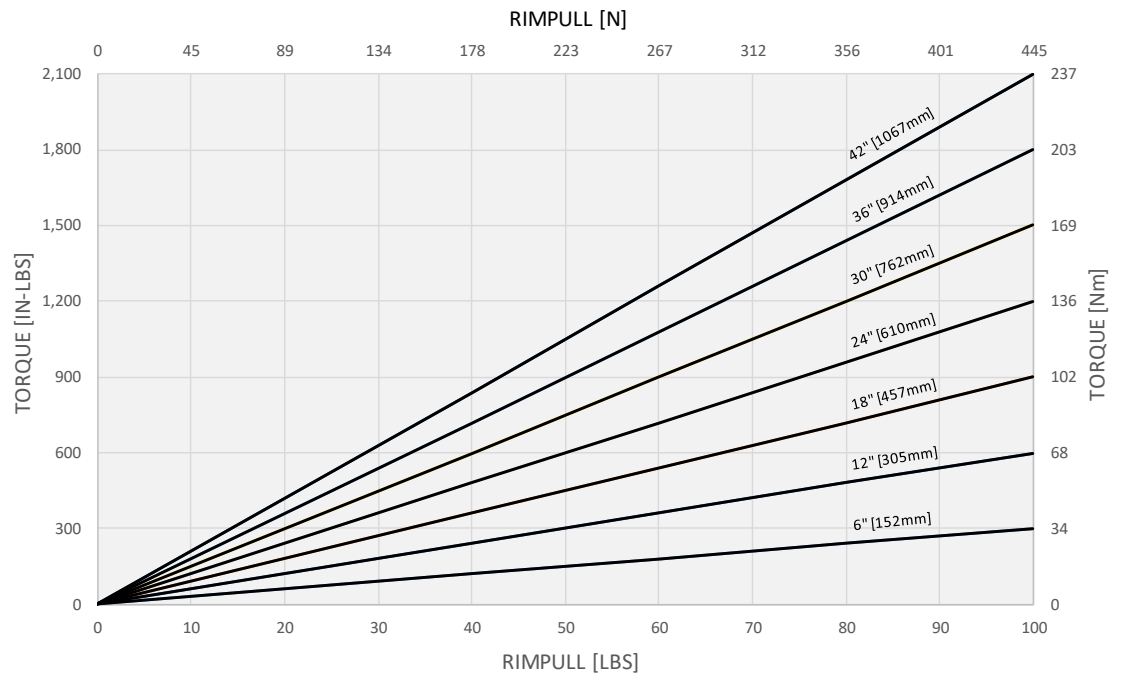

WedgeRock RP SERIES

KEYWAY POSITION

TOP VIEW, QUADRANT IN CLOSED POSITION FOR QUARTER-TURN APPLICATIONS AS SHOWN

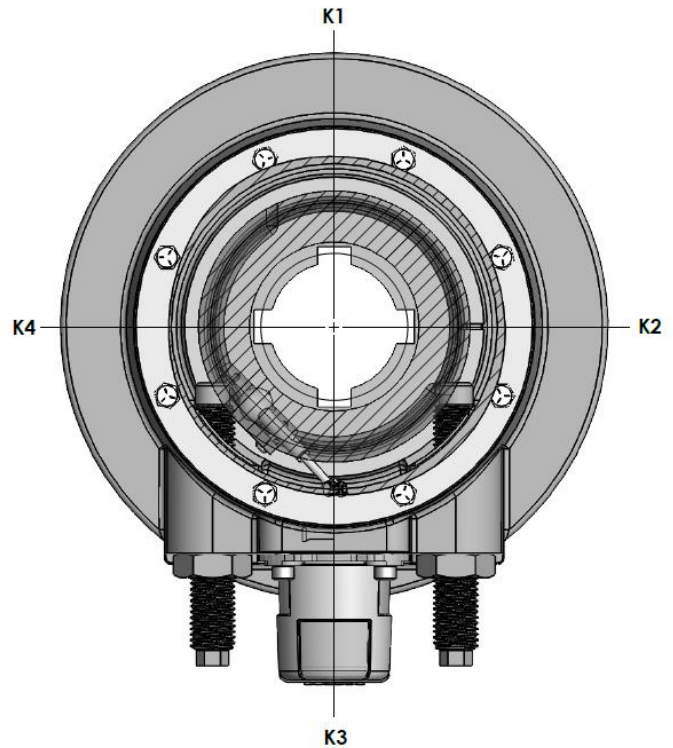

GEAR OPERATOR ORIENTATION TO ALLOW FOR PROPER VENT CONFIGURATION **[STANDARD]**

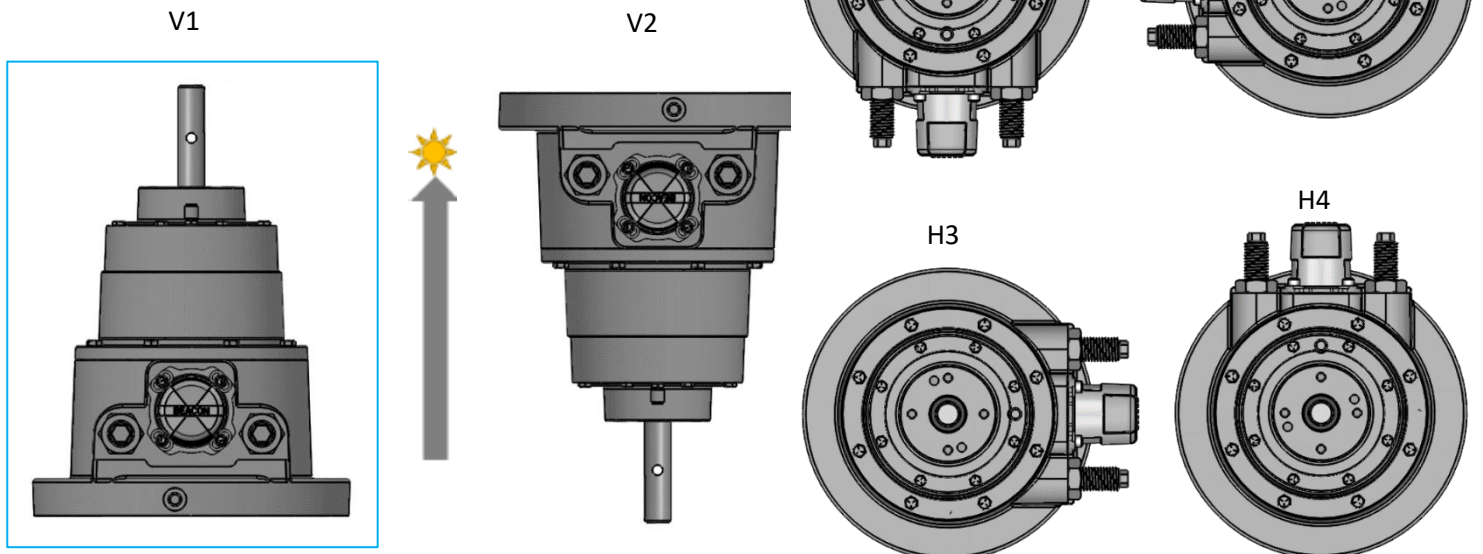

WedgeRock RP SERIES

TEMPERATURE AND SERVICE CONDITIONS

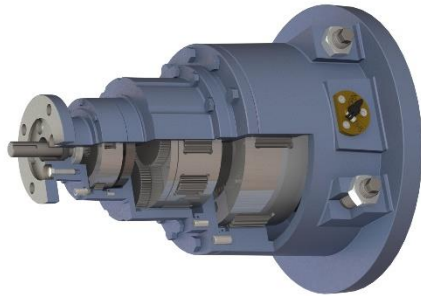

TEMPERATURE SERVICE CONDITIONS				
SERVICE CONDITION	SEAL MATERIAL	LUBRICANT	MIN OPERATING TEMP	MAX OPERATING TEMP
			°F (°C)	°F (°C)
STANDARD SERVICE	BUNA	STANDARD GREASE	-40 (-40)	225 (107)
HIGH-TEMP SERVICE	VITON	HIGH-TEMP GREASE	-15 (-26)	400 (204)
LOW-TEMP SERVICE	LOW TEMP BUNA	LOW-TEMP GREASE	-60 (-51)	225 (107)
COMPENSATED SUBSEA SERVICE	PTFE/BUNA	COMPENSATION FLUID	-40 (-40)	225 (107)

STANDARD COMPONENT MATERIAL SELECTION FOR SPECIFIED ENVIRONMENTS

COMPONENT	SERVICE CONDITION					
	STANDARD PIPELINE		OFFSHORE	SUBSEA		DISTRICT HEATING
	TOPSIDE	BURIED	PLATFORM	SHALLOW	COMPENSATED	CORROSIVE
STOP BASE ¹	DUCTILE IRON	DUCTILE IRON	DUCTILE IRON	DUCTILE IRON	DUCTILE IRON	BRONZE
RP HOUSING ¹	DUCTILE IRON	DUCTILE IRON	DUCTILE IRON	DUCTILE IRON	DUCTILE IRON	BRONZE
OUTPUT HUB ¹	DUCTILE IRON	DUCTILE IRON	DUCTILE IRON	DUCTILE IRON	DUCTILE IRON	BRONZE
PLANET GEARS	ALLOY STEEL	ALLOY STEEL	ALLOY STEEL	ALLOY STEEL	ALLOY STEEL	ALLOY STEEL
SUN GEAR	ALLOY STEEL	ALLOY STEEL	ALLOY STEEL	ALLOY STEEL	ALLOY STEEL	ALLOY STEEL
PLANET CARRIER	ALLOY STEEL	ALLOY STEEL	ALLOY STEEL	ALLOY STEEL	ALLOY STEEL	ALLOY STEEL
HUB BEARINGS	BRASS	BRASS	BRASS	BRASS	BRASS	BRONZE
INPUT SHAFT	STAINLESS STEEL	STAINLESS STEEL	SUPER DUPLEX STAINLESS STEEL	SUPER DUPLEX STAINLESS STEEL	SUPER DUPLEX STAINLESS STEEL	SUPER DUPLEX STAINLESS STEEL
STOPS	ALLOY STEEL	ALLOY STEEL	ALLOY STEEL	ALLOY STEEL	ALLOY STEEL	ALLOY STEEL
JAM NUT(S)	STEEL	SEALED STEEL	SEALED STEEL	SEALED STEEL	SEALED STEEL	SEALED BRONZE
FASTENERS ²	GRADE 5	GRADE 5	316SS	GRADE 5 / 316SS	GRADE 5 / 316SS	316SS
SEALS ³	BUNA	BUNA	BUNA	PTFE/BUNA	PTFE/BUNA	BUNA
LUBRICATION ⁴	GREASE	GREASE	GREASE	GREASE	OIL	GREASE
FINISH ⁵	EPOXY PRIMER	EPOXY PRIMER	EPOXY PRIMER	EPOXY PRIMER	EPOXY PRIMER	N/A

1) Models RP18 and larger may use carbon steel fabrications in place of ductile iron.

2) Standard fasteners for application. Option to use Grade 5, 316SS, B7(M), L7(M), Monel, or other materials per project specification. Grade 5 is zinc plated.

3) Standard seals for application unless otherwise specified. Refer to temperature service condition table.

4) Lubrication per temperature condition. Refer to temperature service condition table.

5) Standard finish unless otherwise specified. Standard epoxy 7-10 mils dft.

Other RP Configurations

RB + RP BASE

RB mounted to a higher torque capacity RP planetary gear to allow input perpendicular from output.



RP Subsea



Subsea planetary gear offers robust concentric design. Compensation to any depth. Non-compensated shallow subsea to 300 ft [100m]. Application Engineered.

RP for Rising Stem

Multi-turn, thrust capable gearbox for rising stem applications. Sandwiches the RP between an RB bevel for input and an RT thrust base to take thrust on the output.



ABOUT WEDGEROCK

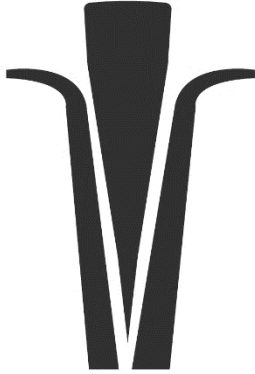

The WedgeRock name and logo symbolize the elegance of a simple and effective design and the grit, focus, and determination required to make things happen – the work required to get big things moving. Pragmatism and hard work are central to our culture and reflected in everything we do.

Don't let our dirty hands and old school approach fool you. WedgeRock brings industry leading innovation to your engineered projects in standard lead times.

With a focused approach, WedgeRock provides solutions for the most demanding torque and thrust application. Whether you need to operate valves thousands of meters below the ocean surface, or a purpose designed gear operator for your valve line, give us a call or send an email to get the partnership started.

OUR MISSION

WedgeRock provides performance engineered actuation solutions for demanding applications.

